

## HIGH TENSION CLAMP

### HIGH TENSION CLAMP

The HTC clamp can be used to attach a Littlite® L-series lamp to a pipe, bar, table or panel edge. The lamp can be attached to the clamp in several ways:

- 1) Positioned vertically on the clamp with the screws, washers and lock washers provided as shown in the drawing
- 2) Temporarily attached vertically or horizontally to the lamp chassis with the (SM) snap mount

Before adhering the snap mount to the clamp, be sure to wipe the clamp surface with an alcohol-moistened wipe and let dry thoroughly.

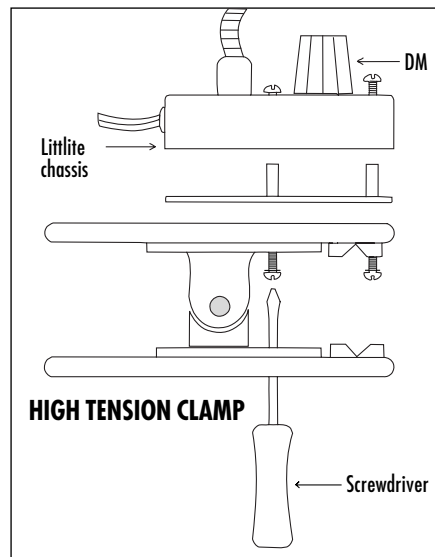

#### USE OF CAE's TRADEMARKS & COPYRIGHTED MATERIALS

Electronic Documents:  
The contents of this disk are copyrighted material. It is the property of CAE, Inc. and is provided as a service for instructional purposes only. Possession does not imply or convey rights to use any information herein, including photos, copy, illustrations, artwork or designs or concepts for any use except to promote products manufactured by CAE, Inc. (Littlite® and Leprecon®). This information is proprietary and may relate to patents or patents pending that are the property of CAE, Inc.

Use of the documents in complete and unedited form is granted to current distributors of Littlite® products. Use of portions, or edited versions of these documents, is not allowed except by CAE's authorization of each specific use. Please send proposed copy to CAE for approval.

Trademark Protection:  
The Littlite® trademark and logo are the property of CAE, Inc. The word Littlite® must always appear with the circled R (®) registered trademark beside it.

Littlite®/CAE, Inc. 10087 Industrial Drive  
P.O. Box 430, Hamburg, MI 48139 USA  
FAX 810-231-1631 PHONE 810-231-9373